

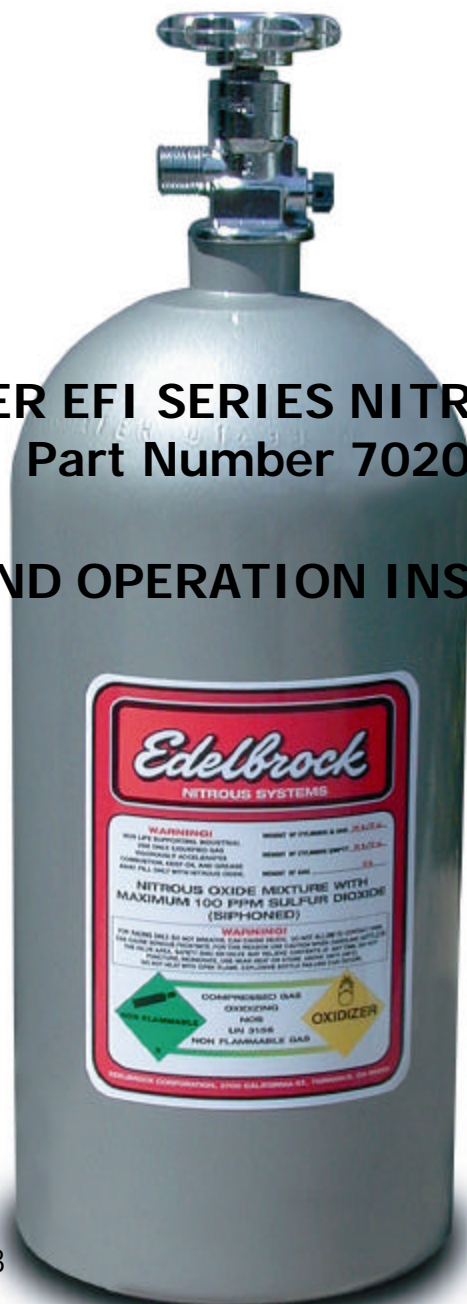

**PERFORMER EFI SERIES NITROUS SYSTEM
Part Number 70205**

INSTALLATION AND OPERATION INSTRUCTION MANUAL



2700 California Street
Torrance, California 90503

E-Mail: Edelbrock@edelbrock.com

Brochure No. 63-0006
Rev. 6/01

Thank You....

...for purchasing an Edelbrock Nitrous Oxide Injection System.

Nitrous Oxide injection is one of the most exciting performance enhancements, for the dollar invested, on the market today. With the use of nitrous oxide come some important safety manual has been written to help you during the installation and use of your Edelbrock Nitrous System. Please read it completely before you install and use your system. Please pay close attention to the beginning of each section. The information contained there specifically pertains

Please take the time to read and understand the following....

By installing your Edelbrock Nitrous System, you indicate you have read this document and you agree

It is the responsibility of the purchaser to follow all installation instruction guidelines and safety procedures supplied with the Edelbrock Nitrous Systems. It is also the responsibility of the purchaser to determine the compatibility of the product with the vehicle or the device on wh

Edelbrock Corporation assumes no responsibility for damages occurring from misuse, abu installation, improper operation, lack of responsible care, or all previously-stated reasons resulting from tibility with other manufacturer's products and/or systems.

Edelbrock Corporation neither recommends nor condones the use of pr Edelbrock Corporation for use on vehicles, which may be driven on public roads or highways, and assumes no responsibility for damages incurred by such use.

Edelbrock Corporation assumes no responsibility for damages incurre manufactured or sold by Edelbrock Corporation on vehicles used for competition or racing.

It is the constant endeavor of Edelbrock Corporation to give our customers the highest quality products le. Edelbrock warrants each new product, except Performer Series Carburetors, Race Division -Back Systems and Performer IAS Shock Absorbers which are warranted separately, to be free from defects in both workmanship and material for a period of one (1) year from the date of purchase, provided that the product is properly insta subjected to normal use and service and that the product is not modified or changed in any way, negligence by customer or installer or used for racing or competition purposes.

Our warranty service and repair facility is located at 2700 California Street, Torrance, California 90503. Customers who believe they have a defective product should either return it to the dealer f was purchased or ship it directly to Edelbrock along with proof of purchase and a complete description -paid. If a thorough inspection of the product by the factory indicates defects in workmanship or material, our sole obligation shall be to repair or replace the product. Warranty covers only the product itself and not the cost of installation or removal.

Edelbrock Corporation shall not be liable for any and all consequential damages the breach of any written or implied warranty pertaining to this sale in excess of the purchase

If you have any questions regarding a product or installation, please contact our Technical Department, toll free at 1-800-416-8628 from 7:00am to 5:00pm PST, Monday through Friday.

Thank you again for choosing Edelbrock Nitrous Systems.



EDELBROCK NITROUS SYSTEMS

PERFORMER EFI SERIES NITROUS SYSTEM

Table of Contents

a.	Before You Install Your Edelbrock Nitrous System	2
b.	What is Nitrous Oxide?	3
c.	Safety Tips for Working with Nitrous Oxide	3

Introduction to the Edelbrock Nitrous Systems Kit

1.1	General Information	4
1.2	Jet Map Information	5
1.3	Engine Operation Considerations	5
1.4	LT1 Camaro Nitrous System Bill of Materials	6

Performer EFI Series Nitrous System Installation

2.1	Nitrous Bottle Mounting	7
2.2	Nitrous Bottle Mounting Instructions	8
2.3	Bottle Orientation	8
2.4	Nitrous Bottle Installation	9
2.5	us Feed Line Mounting	10
2.6	Solenoid Mounting	10
2.7	Nitrous Spray Nozzle Installation	11
2.8	EFI Vacuum "Tee" Installation	12
2.9	Fuel Pressure Safety Switch Installation	12

3.0 Electrical System Installation

3.1	Electrical Components Bill of Materials (BOM)	13
3.2	Nomenclature Descriptions	13
3.3	Electrical System Wiring Diagram	14
3.4	Electrical System Installation Procedures	15
3.5	Relay and Fuse Holder Installation	15
3.6	Arming Switch and Installation	16
3.7	stallation and Wiring	16-17
3.8	Final Electrical Installation Recommendations	17

4.0 Before You Run Your Edelbrock Nitrous System

4.1	Nitrous System Check	18
4.2	Nitrous System Check	18

5.0 Troubleshooting and Routine Maintenance



Caution!!

Before You Install Your Edelbrock

Please read this Installation manual fully before installing this system.

You will need to have available the following tools:

-
- Socket set including ratchets and extensions
 - Screwdrivers
 - Pliers
 - Bench vise
 - Wire crimping pliers, wire strippers
 - Floor jack
 - Vehicle jack stands
 - Safety glasses
 - Valve stem core removal tool

Power Tools

- Power drill
- Drill bits (1/4", 7/16", 1/2" and 3/8")

You should understand the following skills:

- Power tool safety procedures
- Undercar safety procedures
- Proper measuring techniques
- Proper electrical assembly techniques
- Basic engine operation and tuning



Anytime you have questions or concerns with your Edelbrock Nitrous System, please call our technical support hotline at 1-800-416-8628 before you start your engine.

WHAT IS NITROUS OXIDE?

Nitrous Oxide is a cryogenic gas composed of nitrogen and oxygen molecules. It is stored as a “gas over a liquid” which means that both liquid and gaseous nitrous oxide is delivered into your engine. It is _____, which is what produces the added horsepower. By injecting more oxygen (and a corresponding fuel signal), we create the additive that a turbocharger does.

Nitrous Oxide is considered an “oxidizer” and not a fuel. Nitrous Oxide is _____ itself. Because nitrous oxide is a cryogenic, the same safety methods in handling dry ice apply to nitrous. Direct contact with the skin will cause a burn similar to contact with dry ice. The exception in _____ comes from increased breathing hazards associated with the gaseous properties of _____.

Nitrous Oxide is offered for sale in two common grades, which are U.S.P., and *Nytrous Plus*. U.S.P. nitrous oxide is medical grade nitrous oxide. Its common use is dental and veterinary anesthesia as well as use as a propellant in food such as canned whip cream. U.S.P. is not available for sale in _____ would provide no advantage in the making of horsepower over the automotive grade nitrous oxide.

_____ was specifically designed for automotive consumption and differs from U.S.P. in that it contains trace amounts of sulfur dioxide (100 parts per million or “PPM”) added to prevent substance abuse. The Sulfur Dioxide is an irritant to all of your breathing passageways and will cause sore throats. _____ was specifically created for automotive applications and is _____ available for sale to the public at many speed shops across the USA.



de

1. _____ (Nitrous oxide (N₂O) for vehicular use) as continued exposure can _____ of 100 parts per million (ppm) of sulfur dioxide and will cause irritation to nose and throat passageways.
2. When working around a _____-pressure gas including nitrous oxide, take all precautions to ensure that exposure to nitrous oxide is minimized.
3. _____ do not vent nitrous oxide to atmosphere in confined spaces. Only vent nitrous oxide in _____-ventilated and open areas.
4. _____ **cause burns to human flesh** so protect all skin in and around your hands, arms and face. Wear safety glasses and rubber gloves to protect from liquid nitrous oxide.
5. When venting down the nitrous system, vent the line down closest to _____.
6. _____ use any form of Teflon tape as sealant on fitting connections. _____.
7. _____ cleaning components, ensure the clean components are completely dry, free of oils, and solvents. Failure to remove all liquids could cause component or system failure.
8. Always turn the bottle off before making any repairs to the nitrous delivery system.
9. To safely release nitrous oxide in a pressurized line;
 - a. Position vehicle in a well-ventilated, unconfined space.
 - b. _____.
 - c. Slowly loosen the nitrous feed line at the bottle until you hear a light hissing noise.
 - d. Allow the entire nitrous pressure to vent from the line.
 - e. Perform your work on the system.
 - f. Tighten the nitrous line to the bottle.
 - g. _____ the nitrous bottle valve, listening for leaks.
 - h. Perform leak checks on all effected fittings and the bottle fitting.



Anytime you have questions or concerns with your Edelbrock Nitrous System, please call our technical support hotline at 1-800-416-_____
start your engine.

1.0 Introduction to your Edelbrock LT1 Performer EFI Nitrous System

....about this manual!

Within the pages of this manual is information, safety tips and operation instructions for your new Edelbrock Nitrous System. Watch for these symbols to know where

There is safety related information here.



....shows where technical information about your vehicle or specific skills that may help during installation.



....call Edelbrock Technical support hotline for more information.

1.1

The Edelbrock LT1 Camaro Performer EFI Nitrous system (Part Number 70205) is designed for 1993 to 1997 Camaro vehicles equipped with stock or slightly modified LT1 engines. Horsepower and torque increases can vary with equipment upgrades

This system utilizes one nozzle that is installed in the intake boot just after the MAF ter and before the throttle body. The additional fuel needed is supplied by the vehicle's standard fuel system.

s been designed with some flexibility as to where certain components can be located to allow easy installation on vehicles with equipment. The solenoid and microswitch brackets are designed to be manipulated and the electrical components have properly-

This system includes the bottle (shipped empty), bottle feed line and universal footprint steel bottle brackets. The mounting brackets also include rubber insulators to protect the surface of your nitrous bottle while mounted in the brackets. When installing your nitrous bottle, pay close attention to the installation instructions for the location of your bottle. Make sure that the installation of your bottle does not interfere that may lie under the location where you plan to drill holes for mounting the brackets.

Call your local automotive store, motorcycle shop or race track for refilling of your bottle. Trust a professional to properly fill your bottle and reference your installation manual -installing your filled bottle back into your vehicle.

Always take care when handling a full bottle of nitrous oxide. Please reference this manual for further safety measures to take during the handling of a ni

Please follow all safety methods during the installation of your Edelbrock Nitrous ehicle regulations and road laws when using your nitrous

1.2 Jet Map Information

Edelbrock engineering has conducted dyno testing with the Edelbrock LT1 Camaro ensure the horsepower increase the nitrous system is as intended. On a typically stock LT1 engine, you can expect the following

<u>Nitrous/Fuel Jetting</u>	<u>Final Air/Fuel Ratio</u>

80	

The dyno tests were conducted at Edelbrock using a stock LT1 engine. These tests th 950 psi nitrous bottle pressure.

1.3 Engine Operation Considerations

When used correctly, nitrous oxide safely elevates cylinder pressures and temperatures while increasing combustion rate. These characteristics make the engine more tonation. To ensure proper performance, engine and drive line life, the

- **System Jetting**

Never exceed the recommended jetting!! Excessive jetting will result in severe engine

- **Fuel Quality**

Because Nitrous oxide is an oxidizer, fuel selection is critical. Both octane and fuel consistency affect fuel burn rate. The oxidizer quality of nitrous burn rate, so we recommend a high quality of gasoline. We also recommend you use soline every time you use your nitrous oxide system. This will help maintain the same fuel burn rate every time.

- **Ignition Components**

Most aftermarket performance chips increase the vehicle's ignition timing, which can cause detonation with the use of nitrous oxide. Please consult with your chip manufacturer on information regarding the compatibility of your chip with nitrous ox

If your vehicle is equipped with platinum-type spark plugs, we highly recommend they be removed and replaced with the equivalent standard-type spark plugs.

- **Engine System Upgrades**

With all performance modifications, complementary system upgrades to elevate the consistency and longevity of an engine, especially when using nitrous Modifications such as ignition upgrades, free-flowing exhaust, camshafts, cylinder heads, manifolds can all add to the performa

1.4 Performer Kit Bill of Materials



D

- 1 Nitrous fan spray nozzle
- 1 Nitrous fan spray nozzle bulkhead body bolt
- 1 Nitrous fan spray nozzle bulkhead concave nut

Solenoids and solenoid hardware

- 2 Performer Nitrous solenoids
- 1 Solenoid tee 1/8 NPT mm x 1/8 NPT female x 1/8 NPT male
- 1 EFI solenoid mounting bracket
- 4 Solenoid mounting screws (8 x 32 UNC x 5/16")
- 1 Nitrous filter, 4AN x 1/8 NPT, straight fitting, blue
- 1 3AN x 1/8 NPT straight
- 1 90-degree swivel adapter, 4AN male x 4AN female
- 1 24" 3AN steel braided hose 90-degree on one end

Nitrous Pressure Regulator and Hardware

- 1 Nitrous pressure regulator assembly
- 1 1/8 NPT male x 1/8 NPT male union, brass
- 1 1/8 NPT x 3/16" barb, hose adapter fitting
- 1 3 ft x 3/16" rubber fuel hose
- 5 Ratchet hose clamps, 3/16"

Pressure Safety Switch and Hardware

- 1 Fuel pressure safety switch
- 1 -4AN female swivel
- 1 1/16 NPT male x 1/8 N
- 1 1/8 NPT female x #4 AN female swivel

Bottle and Bottle Hardware

- 1 10-lb. Nitrous bottle with gauge and diffuser cap, with external PRD
- 1 Safety Blowdown Tube
- 1 Nitrous bottle bracket set (1 tall, 1 short)
- 2 Rubber insulators (for brackets)
- 1 4AN x 660 Bottle nut and washer
- 2 Nuts, bottle bracket 5/16" x 18 x 1-
- 2 Bolts, bottle bracket 5/16" x 18
- 1 ft. main feed line

- 1
- 1

2.0 Performer System Installations

2.1 Nitrous Bottle Mounting

The nitrous oxide storage cylinder is typically called a “nitrous bottle”. It is an aluminum cylinder, designed and manufactured to withstand very high pressures. The valve on top of the bottle has a pressure relief design that allows easy opening and closing which controls the nitrous

Accurate calibration of your nitrous system depends on the bottle remaining at a stable temperature. In vehicles (such as Corvettes) where the bottle must be mounted in an area subject to direct sunlight, it is suggested that the bottle be shielded with

If the bottle is mounted inside the passenger compartment or in a space that has access to the passenger compartment such as hatchbacks or vehicles that feature fold down rear seats, the pressure relief device (PRD valve) must be vented externally from the cockpit. This procedure will prevent the passenger compartment from filling with a cloud of nitrous oxide, should the safety pressure relief valve rupture. For more information, please contact the tech

Special consideration should be made to protect the bottle installation by not placing the bottle in a known crumple or crash zone within the vehicle. The bottle should be mounted within the seating area of the passenger compartment of a street-

Bottle Valve Handle Pictured



Pressure Relief

Here is the Performer Bottle Valve. Installed on all bottle valves used in Edelbrock Nitrous Systems, is a Pressure Relief Device or “PRD”. It is a safety valve designed to vent the contents of the bottle into the atmosphere in case of a catastrophic event like a collision. It is also installed to prevent the over-pressurization of the bottle. Unsafe bottle pressure is caused by over filling or elevated bottle temperatures.

There are two types of PRD's. Internal piping and external piping. Internal requires no additional parts. The external type requires a safety blowdown tube designed to route the gas, if it ruptures, to the outside of vehicle. The internal type is design to vent directly off the bottle into the

illegal to tamper with or remove this

Bottle Safety Information

1. **Do not** attempt to remove the bottle valve. Please return your bottle to Edelbrock if required to the siphon tube inside the bottle or the bottle valve itself.
2. *heat the outside of your nitrous bottle with an open flame like that of a torch.*
3. *strike the surface of your nitrous bottle with a heavy or sharp object.*
4. *drop your nitrous bottle.*
5. *attempt to grind off or destroy any imprinted markings on the face of the bottle.*
6. *remove, modify or otherwise tamper with the safety valve on the bottle valve.*
7. *attempt to use a bottle that has been damaged or tampered with.*

Before you mount a nitrous bottle in a vehicle intended for use in racing or sanctioned events, check with the sanctioning association or local racetrack for any rules regarding bottle installation. Most associations require the bottle be mounted within the confines of the safety pressure relief cap vented away from the driver's

2.2 Bottle Mounting Instructions

Accurate calibration of your nitrous system depends on the bottle remaining at a stable attitude. Choosing the proper location and orientation for your bottle can greatly affect the overall operation of the nitrous system. Please read the entire bottle mounting instruction section before making your final bottle location decisions.

2.3

Bottle placement is critical to the performance of your nitrous system. It is important to ensure that the bottle valve and siphon tube are assembled to properly orient the bottle in your vehicle and ensure that it picks up liquid nitrous during acceleration. All nitrous bottles are assembled so that the bottom of the siphon tube is the bottom of the bottle, opposite the bottle label.

An Edelbrock nitrous bottle cannot be mounted upside-down. Edelbrock does not recommend a siphon tube bottle for automotive use. If the bottle must be mounted parallel to the axles of the vehicle (sideways), the label must be oriented at approximately 45 degrees toward the front of the vehicle. This orientation will allow the siphon tube to draw liquid nitrous toward the rear and pointing to the lower rear quadrant of the bottle. All of this positioning information is critical to proper operation. It is most important to draw as much liquid nitrous as possible. The siphon tube cannot do this unless the bottle is oriented this way.



The most efficient mounting is the lay-down position with the valve handle toward the front of the vehicle. This position allows the greatest amount of liquid to be used before the siphon tube begins to pick up gaseous nitrous.

2.4 Nitrous Bottle Installation

After you have determined the location and orientation of the nitrous bottle, use the procedure to install the bottle:

Street Car Installations

1. Disconnect vehicle's battery.
2. Determine the location of the bottle within the confines of the rear of the vehicle.
3. Once a mounting location has been determined, raise the vehicle (following safety practices involved in working on a vehicle from under the vehicle) and verify fuel tank(s), brake lines, emissions equipment, or structural members in the way of potential mounting bolt locations.

Note: It may be necessary to remove the fuel tank depending on the location

4. Install the rubber insulators within the bottle brackets.
5. Slip bottle into the mounting brackets.
6. Using the mounting bracket bolt holes as templates, mark an area for each of the brackets with chalk, metal marking pen, scribe, or marking pen to locate the bolt
7. Drill two (2) 3/8" mounting holes for each bracket.
8. If heater blanket is used, brackets must be installed 8 1/2 inches apart from each
9. Install the bottle mounting brackets using "Grade 8" bolts, nuts and flat washers (not included with kit). Use fender washer underneath the vehicle for sheet metal
10. Tighten the mounting bolts using a thread locking compound (not included with kit).
11. Mock up Safety Blowdown tube on bottle to find where tube will go through floor.
12. Mark where tube appears it will go.
13. Using a 1/2" drill bit, drill through floor on mark.
14. Install Safety tube on bottle and cut off excess tube so that only 1 to 2 inches are protruding below floor.



Shown here is a bottle with a bottle bracket properly installed with the rubber insulator. The distance between the bottle brackets is somewhat adjustable. Remember, mount the short bottle bracket at least 1" from the bottom of the bottle, and never cover any of the bottle label with a bottle bracket.

Do not attempt to install the bottle in the bracket without the rubber insulator. The hoop on the bracket is designed to include the thickness of the insulator.

Race Car Nitrous Bottle Installations

Install the bottle brackets in accordance to race track and/or sanctioning body rules. Contact the factory for assistance with meeting sanctioning body rules.

Nitrous Bottle Installations For Vehicles With Hatchbacks Or Trunk Areas That Are Connected With The Passenger

Please contact Edelbrock for more information.

2.5 Nitrous Feed Line Mounting

1. Determine the route your main nitrous feed line will follow. Ensure the path does not run the nitrous feed line too close to the exhaust system, suspension, electrical lines/components or tires.
2. Attach nitrous supply line to bottle.
3. Feed nitrous line along proposed route.
4. Secure nitrous supply line to underside of vehicle.
 - Note:** Stainless steel covering of the main nitrous feed line is very abrasive. Shield painted components or sensitive system components electrical, fuel lines, brake lines or suspension components to prevent them from contacting main feed line. Rubber hose
5. Leave nitrous line loose pending installation of nitrous solenoid.

2.6

Use the following procedures to install the Performer nitrous solenoids:

use Teflon paste only on pipe threads. _____ .

Placement of the solenoid is often limited by the lack of possible mounting locations in the engine compartment. However, if possible, observe the following

Solenoid Safety Information

1. Keep solenoid and lines away from exhaust components.
2. Trial fit the solenoids with all lines attached to ensure a proper fit.
3. Solenoids may be mounted sideways or upside-down, if necessary.

2.6.1 Preparing To Mount Your Solenoids

1. Locate the EFI solenoid bracket, solenoid "tee", and solenoid mounting screws.
2. This solenoid bracket can be modified (bent, twisted and/or cut) to facilitate easier installation in areas with minimal clearance. Please look at the photo on the next page for the solenoid mounting location, and adapt your bracket according to the needs of your particular application.

2.6.2 Nitrous Solenoids Mounting

1. Hold one of the nitrous solenoids securely (like in a bench vise) being careful not to harm the solenoid or block the inlet or outlet port of the solenoid.
2. Install nitrous filter fitting (Blue fitting 4AN X 1/8 NPT) using liquid Teflon, in the inlet port of the nitrous solenoid.
3. Install one of the 1/8 NPT male sides of solenoid "tee", using liquid Teflon, on the outlet port of the nitrous solenoid. The female port of solenoid "tee" should be left open.
4. Install the remaining 1/8 NPT male end of the solenoid "tee", using liquid Teflon, into the inlet port of the second nitrous solenoid. Rotate second solenoid so the inlet port of the second solenoid is facing the same direction as the inlet port of the first solenoid.
5. Install the 3AN x 1/8 NPT (blue straight fitting) into the outlet port of second nitrous solenoid.

6. Install one end of the 1/8 NPT male x 1/8 NPT male nipple fitting, using liquid Teflon, into nitrous pressure regulator inlet port. This is the port at the end of
7. Loosely thread nitrous pressure regulator/nipple assembly into 1/8 NPT female port on solenoid "tee".
8. Using liquid Teflon, install 1/8 NPT x 3/16" barb fitting into nitrous pressure
9. Verify the desired mounting location for the solenoid assembly.
10. After mounting location is determined, tighten all fittings.
11. Remove assembly from vise and mount solenoid bracket to the solenoids.
12. Leave all wiring loose for electrical systems installation.
13. Connect main nitrous feed line to inlet fitting (4AN x 1/8 NPT nitrous filter fitting)

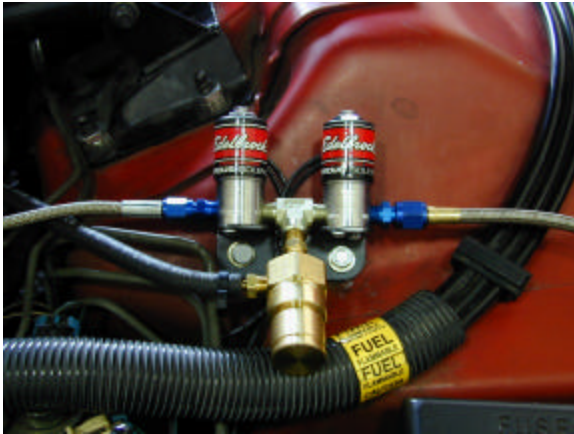

Here is a typical EFI solenoid/regulator assembly, mounted in the engine compartment of a vehicle, -modified EFI sole

Modifications performed to a solenoid bracket depend on many factors. When mounting the solenoid assembly on the vehicle, considerations should be taken regarding any potential interference with the vehicle's systems or

ine length between the Performer LT1 solenoid assembly and the jet fitting on the nitrous spray nozzles is 24 inches. This should be considered when mounting the solenoids.

Nitrous Spray Nozzle Installation

1. Determine nozzle mounting location in intake boot, between the MAF sensor and the throttle body. Make sure the nozzle, mounting collar, and the feed line from sole do not interfere with any systems or components of the vehicle such as the hood latching device.
2. e nozzle will be
3. Remove the intake boot.
4. Drill a 7/16" hole in the intake boot where nozzle placement was
5. Be sure to clean out the rubber shaving made when drilling so as not to suck them through the motor.
6. nozzle mounting nut and collar
7. Using liquid Teflon, install the spray nozzle into mounting collar.
8. spray direction on the nozzle. Be sure the nozzle discharge is towards the vehicles engine.
9. Install the .042 jet into the nozzle
10. Install 3AN line from solenoid outlet fitting to spray nozzle jet fittings and tighten
11. Install the intake



Nozzle should be placed in the intake boot so as to have a clear path to the throttle body. Try to keep the nozzle from having to travel through the bend in the intake boot and as close to the throttle body as possible.



2.8 EFI Vacuum "Tee" Installation

1. Install the .055 jet into the EFI Vacuum "Tee" and tighten the fitting securely.
2. Install vacuum line from the vehicle's fuel pressure regulator.
3. Install vacuum line from the vehicle's fuel pressure regulator onto the center barb fitting of the EFI Vacuum "Tee".
4. Measure the correct length of vacuum line from the barb on the Fuel Pressure Regulator to one port of the EFI Vacuum "Tee". Cut vacuum line and install.
5. Measure the correct length of vacuum line from the barb of the nitrous pressure regulator to the remaining open port on the EFI Vacuum "Tee". Cut the vacuum line and install.

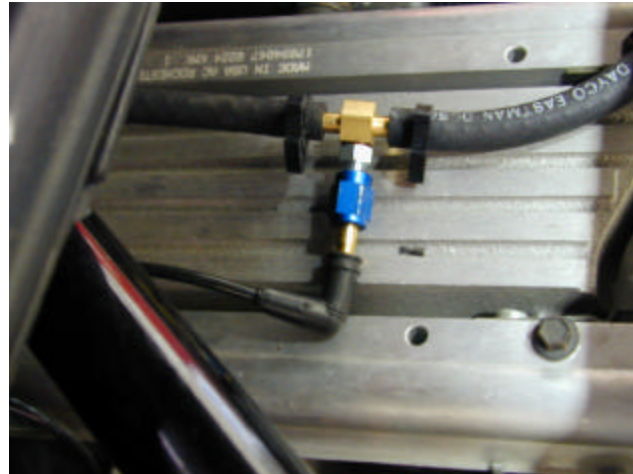

ator to the remaining open port on the EFI Vacuum "Tee". Cut the vacuum line and install.

Fuel Pressure Safety Switch Installation



1. Locate the fuel rail test port fitting.
2. Make sure the vehicle's engine is cool, release pressure in the fuel system by pressing down on the valve in the center of the fitting. This will allow the pressure to escape as well as some
3. After relieving all pressure, remove test port fitting core and install the 1/16 NPT male x 1/8 NPT female brass fitting in it's place, using liquid
4. Using liquid Teflon paste, install Fuel Pressure Safety Switch into the 1/16 NPT male x 1/8 NPT female brass

N On some vehicles, there is no test port fitting, or the location of the test port fitting does not allow ample room for the fuel pressure safety switch to be mounted. These applications will require a hole to be drilled and tapped (1/16 NPT tap supplied with the system) to allow

3.0 Electrical System Installation



3.1 Electrical Components Bill of Materials (BOM)

		Description
1		Activation microswitch
2		Activation microswitch bracket (not shown)
3		Activation microswitch mounting nut
4		Activation microswitch mounting screw
5		
6		Wire harness with integral relay/fuse holder
7		Red lighted toggle switch
8		18/22g female spade connector, Nylon insulated
9		14/16g female spade connector, Nylon insulated
10		14-16g male spade connector, Nylon insulated
11		16/18, splice connector
12		14/16g 3/8" ring terminal, Nylon insulated
13		18/22g ring terminal #10 Stud, Nylon insulated
14		18/22g ring terminal #8 Stud, Nylon insulated (.187)
15		18/22g female spade connector, Nylon insulated
16		15 amp ATO blade fuse

3.2 Nomenclature Descriptions:

Important: The wiring hardware and instructions included with this kit are intended for 12-electrical systems only. Before attempting to wire your Edelbrock Performer nitrous oxide system, examine and follow the wiring diagram on the following page. Please call the Edelbrock technical department with any questions concerning electrical wiring.



When working with electrical systems in your vehicle, it is a good idea to have a service manual is also good practice to have a book that specializes on the specialized techniques required when working with vehicular elect

3.3 Electrical System Wiring Diagram

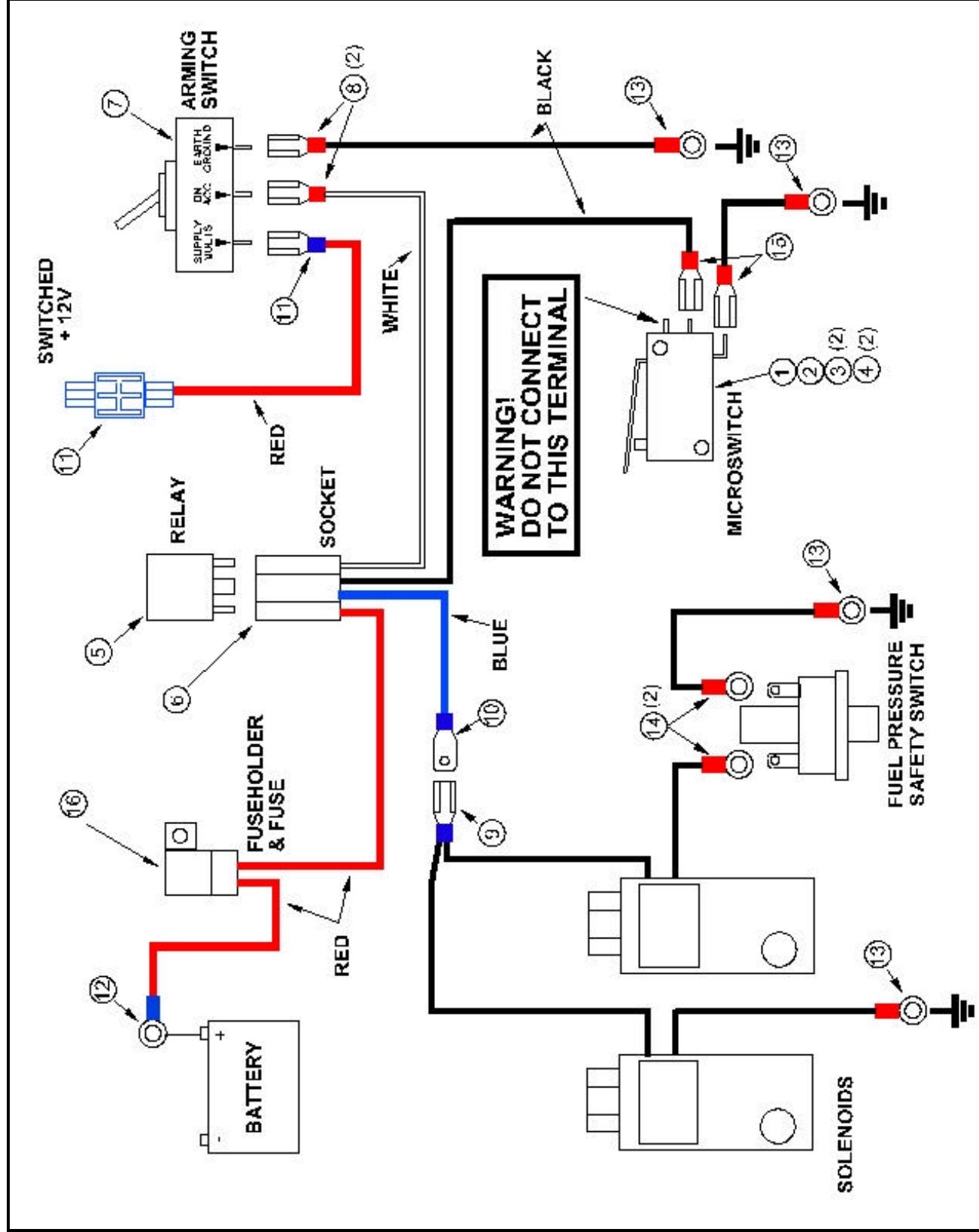

3.4 Electrical System Installation Procedures

Determine the location of the Relay and Fuse Holder wire harness. Most common installations locate these components inside the driver's compartment and close to the fuse panel under the dash. You can also mount the Relay and Fuse Holder and harness close to the battery. However, these connectors are water-resistant not waterproof required when mounting this assembly under the hood of your vehicle.

Wire Schematic Origin and Destination Map

Red			Bat. Volt. Signal	
Red			Underdash Switched 12V	
			Solenoids #1 & #2	
			Fuel PressureSafety	

Relay and Fuse Holder Installation

The wire harness attached to the relay and fuse holder includes 8 feet of color- to make the electrical system installation for your Edelbrock Nitrous System as easy as possible. We recommend that you do not cut any lengths of wires from the wire harness or complete the wiring of the nitrous system until all of the mechanical com securely mounted in their permanent locations.

Once all of the solenoids and switches are placed, then route the un-cut wires from the harness to each location allowing enough wire length on each circuit to not interfere with s, heat sources, brackets, etc. Pay particular attention to sharp edges along the route of your wire harness as they can chafe the wire and cause your system to

After you have accounted for the routing of your wires, follow the Wire Harness Schematic on page 14 and use the Origin and Destination Map as a guide for which electrical connectors are used in each circuit.

you have decided the location of the relay and fuse holder, secure them with fasteners (not included with kit) such as sheet metal screws, bolts and nuts, etc. Allow for some slack in the red wire that connects the relay and fuse holders together.

mounting your relay and fuse holder, make sure the mounting surface is strong enough to support servicing the relay and fuse. Also, ensure you allow for some slack in the wire that joins the fuse holder to the relay mount. This will avoid any potential due to stress on the wire harness.

The fuse is covered by the fuse mount housing.

3.6 Arming Switch and Installation

The arming switch is a red, lighted switch that is a “MASTER” arming switch for your system. Without it, your nitrous system would be “on” all of the time and capable of engaging anytime you go to wide-throttle conditions with your vehicle. The switch, when in the “armed” position, is well lit, therefore it should be placed in an obvious position well within the line of sight and easy reach of the driver. Please refer to the procedures below for the installation.

1. Locate the final position of your arming switch.
2. Drill a .450” (approx. 29/64”) hole for the switch location.
3. Insert the switch from behind the mounting hole and secure with the switch nut.
4. Wire until all other mechanical components are in place. Please see the electrical system installation instructions for further information.

No There is a collar included with the switch for applications that require special

3.7 Microswitch Installation and Wiring

The function of your microswitch is to enable your nitrous system. It should be installed so that the switch is forced closed by coming in contact with the throttle linkage only when the nitrous system must only function at fully-throttle.

MICROSWITCH SAFETY INFORMATION

1. **Do not** allow wiring from the microswitch to come in contact with heat sources on the intake manifold such as EGR risers or passageways.
2. **Do not** run wires to the microswitch that can create interference with the operation of the throttle linkage.
3. The microswitch must be located in such a way as to be clear of the normal operation of the throttle linkage.
4. Do not directly expose the microswitch to liquids such as water or gasoline.



This is a picture of an un-modified and “ready to install” microswitch assembly. The microswitch bracket has several mounting positions available for clocking of the switch. It also is of a universal length and can be attached to several positions on and

3.7 Microswitch Installation and Wiring (Continued)

The bolts used to attach the microswitch have extra length to allow for spacing the microswitch away from the bracket to offer a level of adjustability of the microswitch. If necessary, of the microswitch, we recommend trimming the bolts for

Due to the wide variety of throttle linkage combinations in use, it is impossible to supply a microswitch bracket custom-tailored to each application. The universal bracket-supplied will need to be modified to fit your specific application.

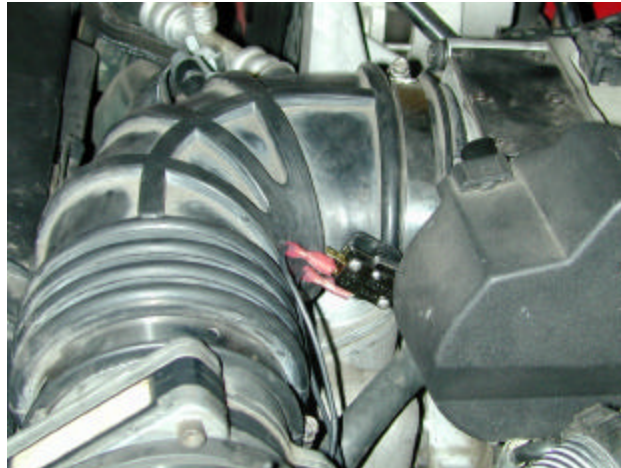

Here is the microswitch assembly mounted for use. It is an example of one of many ways in which to mount a microswitch

The microswitch bracket allows for many different mounting positions. The microswitch bracket can be modified to clear almost any potential interference around the throttle linkage.

Please look for potential microswitch mounting locations and adapt your microswitch bracket according to the needs of your part

The microswitch bracket is drilled to allow many different switch mounting positions. Always position the microswitch to be positioned in such a manner that it will engage the throttle linkage without interfering with its normal operation. The bracket may be manipulated (bent, twisted, and/or cut) to best suit your combination. Adjust the microswitch so the actuation arm is triggered by throttle linkage making sure all wiring and the bracket do not interfere with the s

Adjust microswitch to ensure the actuation arm “clicks” at the same point you linkage reaches wide open throttle against the throttle stop. _____

3.8 Final Electrical Installation Recommendations

At this time, it is advised that you double-

1. -check all wires so that they do not come in contact with any heat sources
2. -check the wires that lead from the microswitch to ensure they do not interfere with the operation of the throttle linkage.
3. Make sure the relay and the fuse are serviceable and mounted securely.

You are ready to hook up your battery and prepare your vehicle to run.

4.0 Before You Run Your Vehicle Using Your Edelbrock Nitrous System

You have just completed the installation of your Edelbrock Nitrous System. It is time to perform some basic system checks to ensure all of the work you have done is correct and ready to operate properly. The following procedure is designed to validate the operation of your nitrous

Note: Before performing steps 1 thru 4, make sure that the nitrous bottle is closed and

4.1 Fuel System Check

1. Hook up all battery leads.
2. -check all wires and leads for signs of heat and proper connections.
3. Turn the ignition key to the engine "on" position without starting the engine.
4. Inspect fuel rail where Fuel Pressure Safety Switch has been installed for any leaks.

4.2 Nitrous System Check

1. With the vehicle's engine running, slowly open nitrous bottle valve.
There should be no change in engine idle speed. If idle speed changes, bottle valve immediately and refer to the "Troubleshooting -21.
2. Inspect nitrous lines and fittings for leaks using a soapy water mixture and a small
3. If any of the fittings/connections show bubbling around the attachment nut threaded area of the fitting, shut the nitrous bottle valve off immediately and dry the service to that particular fitting connection.
4. If the engine idle does not come up, and all of the fittings appear to be leak- you have successfully completed the installation of you Edelbrock Nitrous System.

5.0 Troubleshooting and Routine Maintenance

How to use our Troubleshooting Flowchart:

The troubleshooting of a nitrous system is basic and straightforward. The symptom chart is divided by symptom, cause and action required. Determine your problem (symptom), identify the potential problem (cause) and correct the problem (action required).

Symptom #1... *Change in engine speed when nitrous bottle valve is opened.*

1. Malfunctioning nitrous solenoid.
 - a. Refer to solenoid inspection and repair on page 21.
 - b. Repair/replace solenoid.
2. Contamination in nitrous solenoid.
 - a. Refer to solenoid inspection and repair on page 21.
 - b.

Engine runs excessively rich when system is activated.

1. Nitrous bottle valve not fully opened.
 - a. Check bottle valve.
 - b. Open valve fully.
2. Nitrous bottle mounted improperly.
 - a. Mount bottle properly. See manual pages 7-8 for more information.
3. Plugged nitrous filter.
 - a. Clean and/or replace nitrous filter.
 - b. See nitrous solenoid symptom #1.
4. Low bottle pressure.
 - a.
 - b. Bottle should be 10 lbs. above empty, bottle weight listed on bottle label
 - c. Bottle temperature.
 - d. Maintain 80 to 85 degrees of bottle surface temperature.

No change in performance when system

1. System wired incorrectly.
 - a. Compare wiring to schematic. See page 14.
 - b. Wire per instructions.
2.
 - a. Connect test light to battery "+" (positive) terminal. Check for continuity at grounds.
 - b. Tighten/repair loose
3. No power to arming switch.
 - a. With ignition "on", connect test light to battery "-" (negative) terminal. Check for power at pole #1 on arming switch.
 - b. Repair wiring as necessary.
4. Malfunctioning arming switch.
 - a. With ignition "on", turn arming switch "on." Connect test light to battery "-" terminal. Check for power at terminal #1 wire on arming switch.
 - b. If power is present, replace arming switch.
5. Malfunctioning microswitch.
 - a. Turn arming toggle "off". Open (lever is not being activated) throttle microswitch, check for continuity between microswitch wiring terminals.
 - b. If continuity is present, replace microswitch.

6. Inadequate nitrous supply.
 - a.
 1. Bottle should be 10 lbs. above empty bottle weight listed on bottle label when full.
 - b. Check bottle pressure.
 1. -950 psi for optimum system performance.
 - c. Check bottle temperature.
 1. 0 to 85 degrees of bottle surface temperature.
 - d. Check bottle valve.
 1. Open valve fully.
 - e. Check bottle orientation. See page 8.
 1. Mount bottle properly.
7. Loose nitrous solenoid wiring.
 - a. Inspect solenoid wiring. See pages 13-14 for wiring information.
 - b. Repair wiring as necessary.
8. Malfunctioning nitrous solenoid.
 - a. Inspect solenoid wiring. See pages 13-
 1. Repair wiring as necessary.
 - b. Inspect solenoid. See symptom # 2.
 1. Rebuild/replace solenoid.

Engine detonates mildly when system is activated.

1. Inadequate octane fuel.
 - a. Verify what gasoline you use.
 1. -
2. Spark plug heat range too high.
 - a. Verify what heat range the spark plug is, and how it functions in a high load, high performance application.
 1. Install a performance spark plug.
 2. Reduce spark plug heat range.
3. Too much nitrous flow.
 - a. Verify the size of the nitrous jet.
 1. Install the proper nitrous jet.
 - b. Check bottle temperature and pressure.
 1. very nitrous usage that you only use nitrous when the temperature and pressure of your bottle are correct.

Symptom #6... Vehicle surges under acceleration when system is activated.

1. Inadequate nitrous supply.
 - a.
 1. Weight should be 10 lbs. above empty bottle weight listed on bottle label when full.
 - b. Check bottle temperature.
 1. Within 5 degrees of bottle surface temperature.
 - c. Check bottle valve.
 1. Check for leaks.
 - d. Check bottle orientation. See pages 7-8.
 1. Mount bottle properly.

Solenoid inspection and maintenance.

1. Close valve on nitrous bottle.
2. Make sure all nitrous supply lines are free of pressure before removal of any system solenoid.
 - a. Empty main nitrous supply line at the nitrous bottle. Take care to not breathe or expose your face to nitrous oxide.
 - b. **Do not open pressurized fuel lines over a hot engine.**
3. Remove the solenoid from the engine and securely clamp it into a vise, taking great care not to damage the solenoid.
4. Remove the solenoid cover, retaining nut from top of the nitrous solenoid.
5. Remove coil and housing from nitrous solenoid base.
6. Remove the stem from nitrous solenoid base. Do this by using a solenoid stem removal tool or by "double nutting" the stem and unscrewing the stem with **pliers on solenoid stem**; damage to the stem will result.
7. Remove the spring and plunger from the solenoid base paying close attention to the plunger seal.
8. Examine the plunger seal for swelling, cuts and abrasions. The seal surface should be flat, except for a small circular indentation in the center of the seal.

A seal that has been contaminated or over-pressurized will bulge from exposure to chemicals other than nitrous oxide. It can appear to extend down from the plunger and be mushroom-shaped. A contaminated seal may return to its original shape if left out in the open for approximately 48 hours. It may then be returned to service. If it does not return to its original shape, it should be replaced.
9. Clean the solenoid body. **Do not use an oil-based solvent to clean any part of the solenoid.** Use a carburetor or electrical contact cleaner. Remove any contaminants that may be present. Make sure solenoid body is clean, dry and free of oil.
10. Re-assemble the solenoid by reversing disassembly procedure. Re-install the plunger, plunger spring, O-ring, plunger and piston spring.
11. Re-assemble solenoid by reversing disassembly procedure.



Edelbrock Nitrous Systems

This page is left for notes:



2700 California Street
Torrance, California 90503