



COLD AIR SYSTEM

Installation Instructions for:
Part Number 21-416
2001-2003 Acura 3.2CL
2000-2003 Acura 3.2TL
1998-2002 Honda Accord 6 Cyl.

ADVANCED ENGINE MANAGEMENT INC.

2205 126TH Street, Unit A Hawthorne, CA. 90250

Phone: (310) 484-2322 Fax: (310) 484-0152

www.aempower.com

Instruction Part Number: 10-226

2001 Acura CL 3.2L J32A1 C.A.R.B. E.O. #D-392-11

2002-2003 Acura CL 3.2L J32A1 C.A.R.B. E.O. #D-392-18

2000-2001 Acura TL 3.2L J32A1 C.A.R.B. E.O. #D-392-11

2002-2003 Acura TL 3.2L J32A1 C.A.R.B. E.O. #D-392-18

1998-1999 Honda Accord 6 Cyl. J30A1 C.A.R.B. E.O. #D-392-5

2000-2001 Honda Accord 6 Cyl. J30A1 C.A.R.B. E.O. #D-392-11

2002 Honda Accord 6 Cyl. J30A1 C.A.R.B. E.O. #D-392-18

© 1999 Advanced Engine Management, Inc.

Congratulations! You have just purchased the finest Air Induction & Filtration system for your car at any price!

The **AEM** Cold Air System is the result of extensive development on a wide variety of cars. Each system is engineered for the particular application. The **AEM** Cold Air System differs from all others in several ways. We take the inlet air from outside of the engine compartment where the inlet air is considerably cooler than the hot underhood air. The cooler inlet air temperature translates to more power during the combustion process because cool air is denser than warm air. **AEM** has conducted extensive inlet air temperature studies and we have seen temperature reductions of up to 50 degrees by pulling air from outside of the engine compartment. The *air mass* flow to the engine is increased because of the increased airflow *and* reduced inlet temperature, which translates to more power. The **AEM** Cold Air Systems are **50 State Street Legal** (some models and years still pending) and come with complete instruction for ease of installation.

Our system is constructed of lightweight aluminum and then painted with a zirconia based powder coat for superior heat insulating characteristics. The aluminum will not crack in extended use like plastic and it is actually lighter than plastic. The tube diameter and length are matched for each engine to give power over a broad rpm range. Unlike the plastic systems that use a continually diverging cross section, we take advantage of the acoustical energy in the duct to promote cylinder filling during the intake valve-opening event.

Bill of Materials for:

Part Number 21-416

98-02 Honda Accord V6, 00-03 Acura 3.2TL, 01-03 Acura CL 3.2L

QTY.	Part Number	Description
1	2-429	Upper Inlet Pipe
1	2-430	Lower Inlet Pipe
1	21-102	2.75" AEM Air Filter & Hose Clamp
1	5-272	2.75" x 2" Connector Hose
1	5-275	2.75" x 3" Connector Hose
1	103-BLO-4020	2.5" Hose Clamps
4	103-BLO-4420	2.75" Hose Clamps
2	1228599	Rubber Mount
3	559999	6x25x1mm Washer
4	444.460.04	6mm Nyloc Nut
2"	65116	1/2" Breather Hose
2	99024.032	1" Hose Clamps
1	8-100	Loom Clamp
1	10-226	Instructions
1	10-922S	AEM Decal
1	10-905	Warning Decal
1	11-416	E.O. Decal

Read and understand these instructions BEFORE attempting to install this product.

1) Getting started

- a) Make sure vehicle is parked on a level surface.
- b) Set parking brake.
- c) Disconnect negative battery terminal.
- d) If engine has run within the past two hours let it cool down.

2) Removing the stock air inlet system

- a) Remove the stock air box assembly and attaching hardware from inside the fender well.
- b) Disconnect the breather hose and the Fuel Injection Air Control System hose from the air inlet tube.
- c) Loosen and remove the air inlet tube from the throttle body.
- d) Jack the front of the vehicle and support using properly rated jack stands.
 - i) Remove the lower front splashguard.
 - ii) Remove the front left tire and remove the inside splashguard (inner fender liner).
- e) Remove the resonator from underneath the vehicle.

3) Installing the cold air system

- a) Install the 2" long connector hose on the throttle body end of the primary pipe. That is the end closest to the breather nipple.
 - i) **Accord** - Install the 2.50" hose clamp on the connector hose and loosely tighten. Install a 2.75" hose clamp onto the other end of the connector hose.
3.2CL/TL – Install the 2.75" hose clamp on the connector hose and loosely tighten. Install a 2.75" hose clamp onto the other end of the connector hose.
- b) Install the pipe onto the throttle body.
 - i) The support tab on the inlet pipe will line up with a threaded hole on the inner fender well. Install the rubber isolator mount and attach the air inlet tube onto the rubber mount. Install the large fender washer and the lock nut onto the isolator mount stud and snug it down. **Failure to install the rubber mount will void all warranties of the Cold Air System.** Below is a diagram of how the rubber mount should be installed.

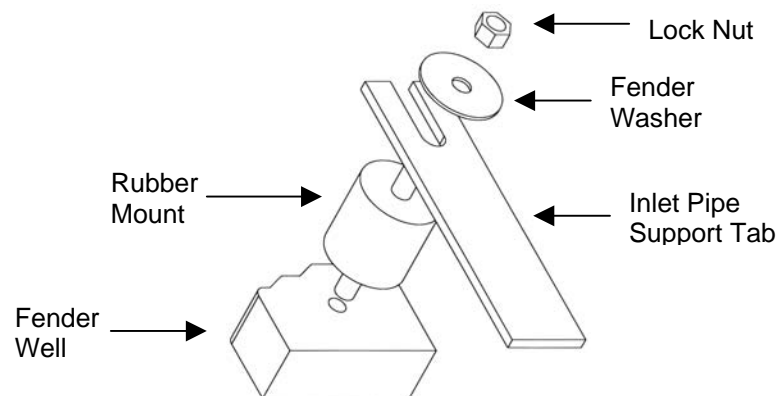

- c) Install another connector hose onto the other end of the inlet pipe. Gently tighten two hose clamps around this connector hose.
- d) Install the secondary inlet pipe through the hole that was left exposed upon removal of the O.E. resonator. Slide the end of the pipe into the connector hose and gently tighten the hose clamps.
 - i) The support tab on the lower inlet pipe should be aligned with a hole on the lower inner fender well just below the headlight. On some vehicles there will be a plastic wire loom using this hole, if so remove it. Install the second rubber isolator mount through this hole. Use a large fender washer and a lock nut to secure it to the vehicles body. Attach the support tab to the isolator mount stud using another large fender washer and locking nut. **Failure to install the rubber mount will void all warranties of the Cold Air System.** Refer to the diagram above for proper installation of the rubber isolator mount.
- e) Install the **AEM** filter on to the end of the inlet tube. Push the filter on around 2 inches over the inlet pipe and install one hose clamp to secure the filter on to the inlet pipe. Once fitment is checked, you can either push the filter on to the inlet pipe more or less depending on clearances.

- f) Install the 2" section of breather hose onto the O.E. breather hose. Then slide this onto the nipple on the inlet pipe. Install two hose clamps to secure the breather hose. Slide the Fuel Injection Air Control System hose onto the nipple on the backside of the inlet pipe. Note: some adjustment might be necessary in order for the breather hose to fit properly.
- g) Install the loom clamp that is provided in the kit around the cruise control cable and attach it to the battery clamp. Secure this with the nut provided in the kit.
- h) Adjust the air inlet system for the best possible fit. Be sure that the pipe and filter are clear of any obstructions. Make sure that there is ample clearance around every component of the cold air system.
- i) Tighten all remaining hose clamps and the nut on the rubber mount.

4) Re-assemble the vehicle

- a) Install the left fender liner and the lower front splashguard. ***Failure to install the plastic splashguard will result in diminished performance and increase the potential for engine damage due to water ingestion in rainy conditions.***
- b) Install the front left wheel and lower the vehicle.
- c) Inspect the engine bay for any loose tools and check that all fasteners that were moved or removed are properly tight.
- d) Start engine and perform a final inspection before driving the vehicle.

For technical inquiries please E-Mail us at: tech@aempower.com