



631301 DISTRIBUTION BLOCK

INSTALLATION INSTRUCTIONS

The 631301 valve is a distribution block. It features an integrated low pressure warning light switch. When there is a loss of pressure the contact switch grounds out and connects the circuit. The switch has a single wire that connects to the instrument panel's brake warning light. It does not proportion fluid and must be used in conjunction with a hold off valve. It was originally installed onto drum brake vehicles with dual reservoir master cylinders.

4-WHEEL DRUM CONFIGURATION (USING 631300 VALVE)

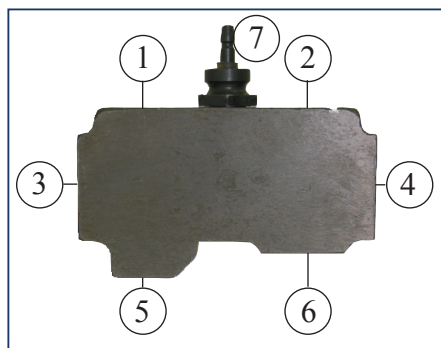

1. OUT to Rear Brakes
2. IN from 631300 Valve (Front of Master Cylinder)
3. IN from Rear of Master Cylinder
4. OUT to Front Brake
5. Mounting Bracket
6. OUT to Front Brake
7. Brake Dash Light

4-WHEEL DISC CONFIGURATION (NO 631300 VALVE)

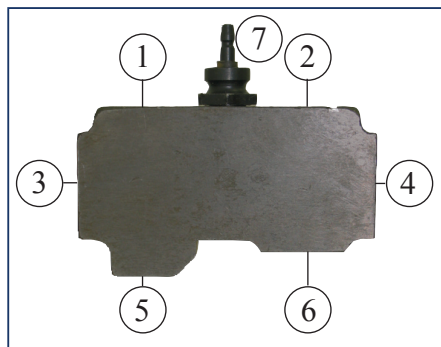

1. OUT to Rear Brakes
2. IN from front of Master Cylinder
3. IN from rear of Master Cylinder
4. OUT to Front Brake
5. Mounting Bracket
6. OUT to Front Brake
7. Brake Dash Light

NOTE:

Some IN/OUT line connections to front brakes may vary due to OEM variations by year.

WARNING

Proper operation of your brakes is essential for your safety and the safety of others. Any brake service should be performed ONLY by persons experienced in the installation and proper operation of brake systems. It is the responsibility of the person installing any brake component or kit to determine the suitability of the component or kit for the particular application. After installation, and before operating your vehicle, be sure to test the function of the brakes under controlled conditions. DO NOT DRIVE WITH UNTESTED BRAKES!