

Installation Instructions for 52135 Mustang Fan



INSTALLATION INSTRUCTIONS:

(Fan may be attached to the radiator horizontally or vertically.)

Mount fan with brackets using either the bolt-on or clamp-on method, and affix the threaded rods and brackets to the fan accordingly.

NOTE:

- Use star nuts as shown to stabilize the threaded rods.
- The thermostat sensing bulb **MUST** contact the radiator surface for accurate temperature readings.
- To avoid damage, do not over-tighten fan to radiator.

REQUIRED CONNECTIONS:

1. Disconnect vehicle battery.
2. Attach the positive (+) terminal to a low-amp 12-volt positive (+) power source (such as fuse box), using the wire provided in the fan kit.

OPTIONAL CONNECTION: Attach the positive (+) terminal to an ignition source to stop the fan unit from operating after the engine is tuned off.

3. Connect the "B" terminal to a high-amp 12-volt positive (+) power source, such as the positive (+) side of battery or alternator, using the wire and inline circuit breaker included in kit. Circuit breaker is marked for proper installation.
4. Connect the "G" terminal to ground (such as chassis, negative (-) side of battery) using the wire provided in the kit.
5. With the wire and 3-way connector provided, splice into the A/C clutch positive (+) wire. Connect the other end of the wire to the "C" terminal of the control box. **NOTE:** Air conditioning relay activates fan when A/C is turned on.
6. Adjust thermostat to desired temperature within 180-240° range.

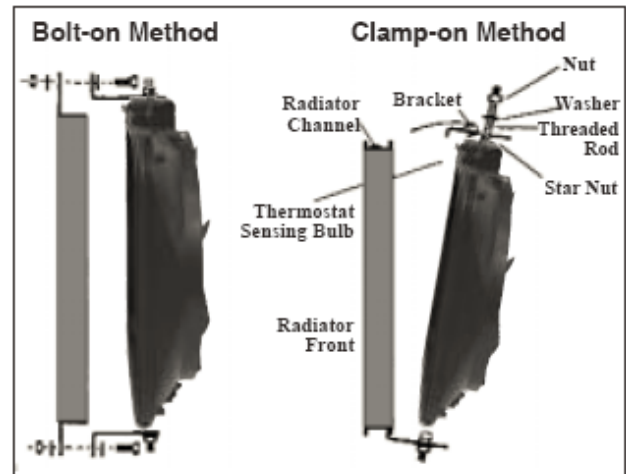

MANUAL SWITCH INSTALLATION OPTION (permits on/off operation manually).

(Switch not included – Must purchase separately)

1. Attach the "M" terminal to terminal 1 on the switch.
2. Attach terminal 2 to 12-volt positive (+) source.
3. Attach terminal 3 to ground.

Note: To prevent the fan from thermostat activation, omit the lead to the positive (+) terminal of the control box, B, G & M must remain connected.

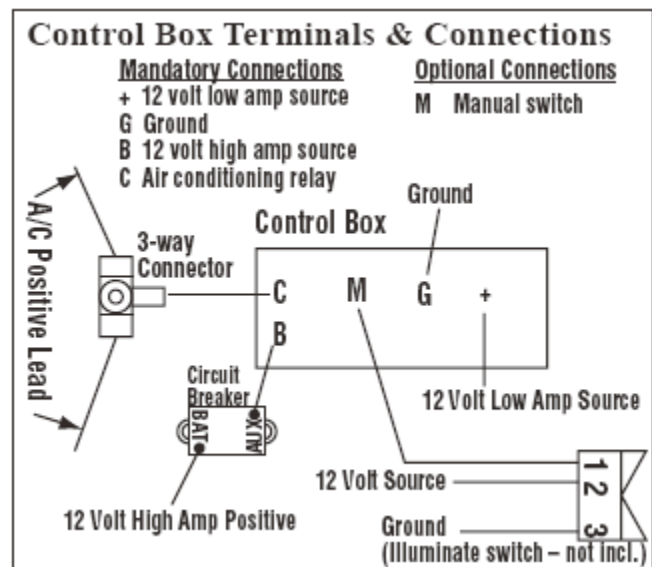

IMPORTANT: If not using an illuminated switch, disconnect the switch ground.



1-800-345-4545 jeps.com

The included bracket (see image A) is used for the overflow tank. Using your original screws, mount the bracket to your radiator. Using the angle brackets (see image B) attach your fan to the top of the radiator, positioning it between the overflow tank and radiator tank.



A.



B.