

Installation Instructions for 10565 Universal Electric Water Pump Relay Kit

WARNING! Check for leaks before starting your vehicle.

Installation Instructions:

For best results mount the Water Pump Relay in close proximity to the electric water pump.

Be sure to route wires in a manner so that they do not chafe on any sharp metal edges and use proper terminals and connectors at all connecting points to insure proper water pump function. Use wire nuts, solder and heat shrink tubing or crimp connectors to make all of the electrical connections. We do not recommend the use of electrical tape as a means to make and hold connections together.

1. Secure the relay assembly with the included sheet metal screw. You may use this attachment for the GREY ground wire if it is making direct contact with a ground, such as the chassis or underbody sheet metal. If the relay is attached to a plastic or other non-conductive material be sure to route and secure the GREY wire ground to a known ground.
2. The circuit breaker should be mounted close to the positive 12 volt power source.
3. Attach the PURPLE 12-gauge wire from the relay to the water pump positive connection as indicated by water pump manufacturer.
4. Attach the 18 gauge YELLOW wire to an independent (off/on) water pump switch which is powered by a fused 12 volt source.
5. Cut the large 10 gauge RED wire to the necessary length and attach to a known "hot source", such as the battery or + lead at the starter solenoid.
6. Attach the remaining length of red wire between the unused side of the circuit breaker and the battery + source.

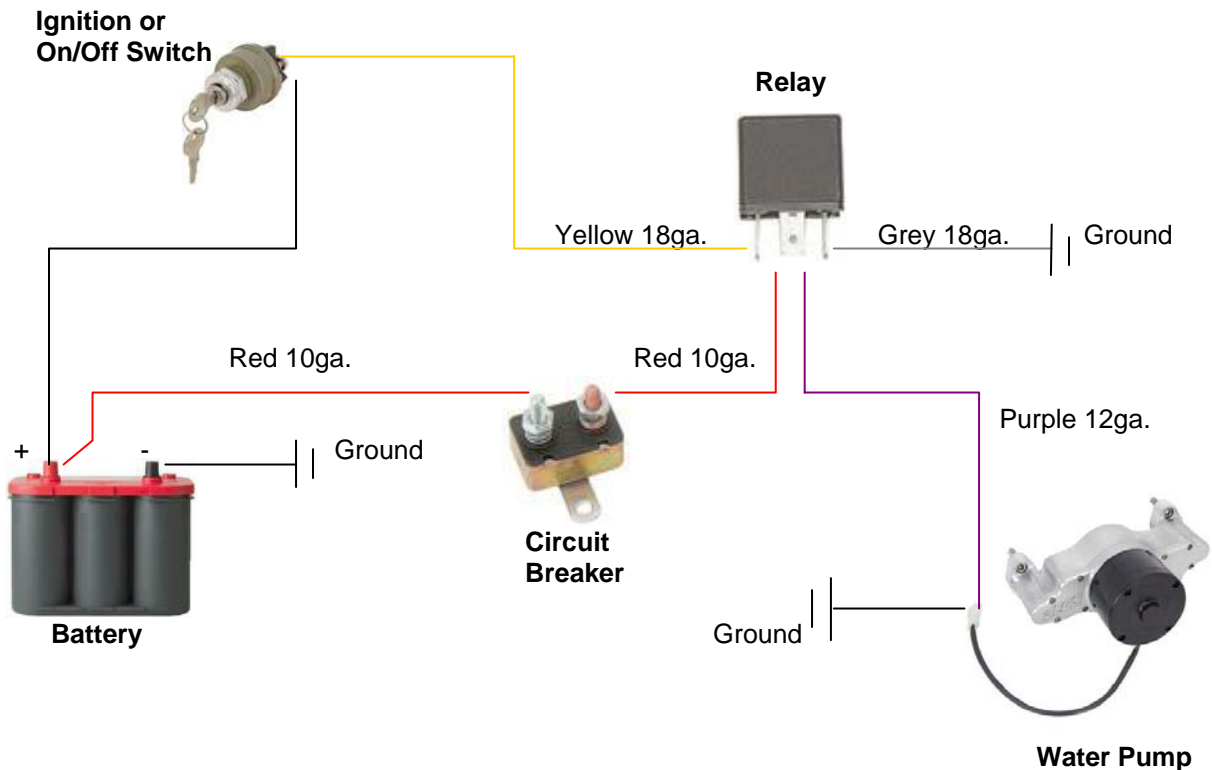

1-800-345-4545 jeps.com