

Section 2: Specifications

Features and Dimensions

1. Forward shift provision. Requires use of separate 'forward' conversion shifter assembly. Not included.
2. Standard reversible rear shifter. Custom offset shifters to achieve factory shift hand positions - available through TREMEC dealers.
3. Reverse light switch.
4. Mechanical speedometer output.
5. Neutral safety switch.
6. Ford or GM-style 4-speed bolt pattern.
7. Common mechanical clutch release bearing retainer. Can be converted to hydraulic clutch release using aftermarket systems - available through TREMEC dealers.
8. Torque-arm mount.
9. Electronic speedometer output.
10. Fluid drain and spill ports.
11. Slip yoke output.
12. Transmission mount location.

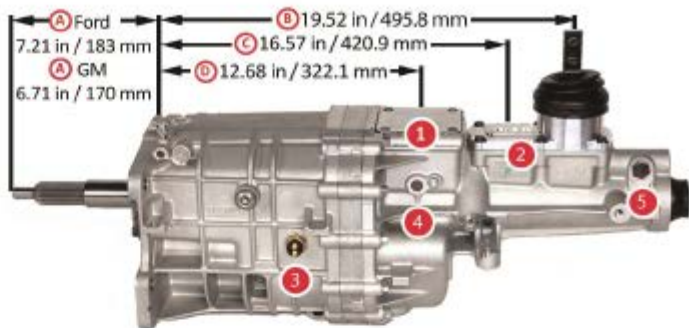

- A. Input shaft length from front face of transmission.
- B. Standard shifter location from front face of transmission.
- C. Optional shifter location from front face of transmission.
- D. Optional shifter location from front face of trans. Requires use of separate 'forward' conversion shifter assembly. Not included.
- E. Height at transmission face.
- F. Width at transmission face.
- G. Trans mount pad from front face of transmission.
- H. Overall length.
- I. Trans mount pad to main shaft centerline.