

Installation Instructions for 555-63012 & 555-63014 Vacuum Reserve Canister with Jeg's "Just-Able" Integral Mounting System

The JEG'S "Just-Able" mounting system is extremely easy to use.

1. Simply drill two 1/4" holes with clearance. Use a letter "F" drill bit (0.2570") or 17/64" drill bit (0.2656") in your selected mounting position. Do not drill the mounting holes closer than 1" centers or further apart than 5" centers or if you prefer we offer an optional mounting T-Bracket designed for this JEGS "product": # 555-51133 Clear Anodized or # 555-51134 Polished.
2. Place one each of the stainless steel lock and flat washers onto the stainless steel bolt and insert the assembly through the drilled hole. Start a stainless steel nut onto the bolt and repeat for the second mounting hole.
3. Install rubber grommet into the large hole in the top of vacuum canister. Using assembly lube or equal product applied to the inside of the rubber grommet push in the plastic check valve. Install the 90° threaded hose fitting and the 1/8" pipe plug into the desired 1/8" threaded ports in the top of the vacuum canister.
4. Slide the vacuum reserve canisters mounting slot over the exposed nuts (Suggestion: spray a light coating of silicone or equivalent product on the surface of the nut or bolt head to aid in the installation) and position the vacuum reserve canister in the desired location and tighten the bolts.
5. Optional: You can also mount the bolts in the reverse direction with the head of the bolt in the "Just-Able" slot.
6. Attach the plastic check valve on the vacuum canister to engine vacuum. Attach the 90° hose fitting on the vacuum canister to the brake booster.

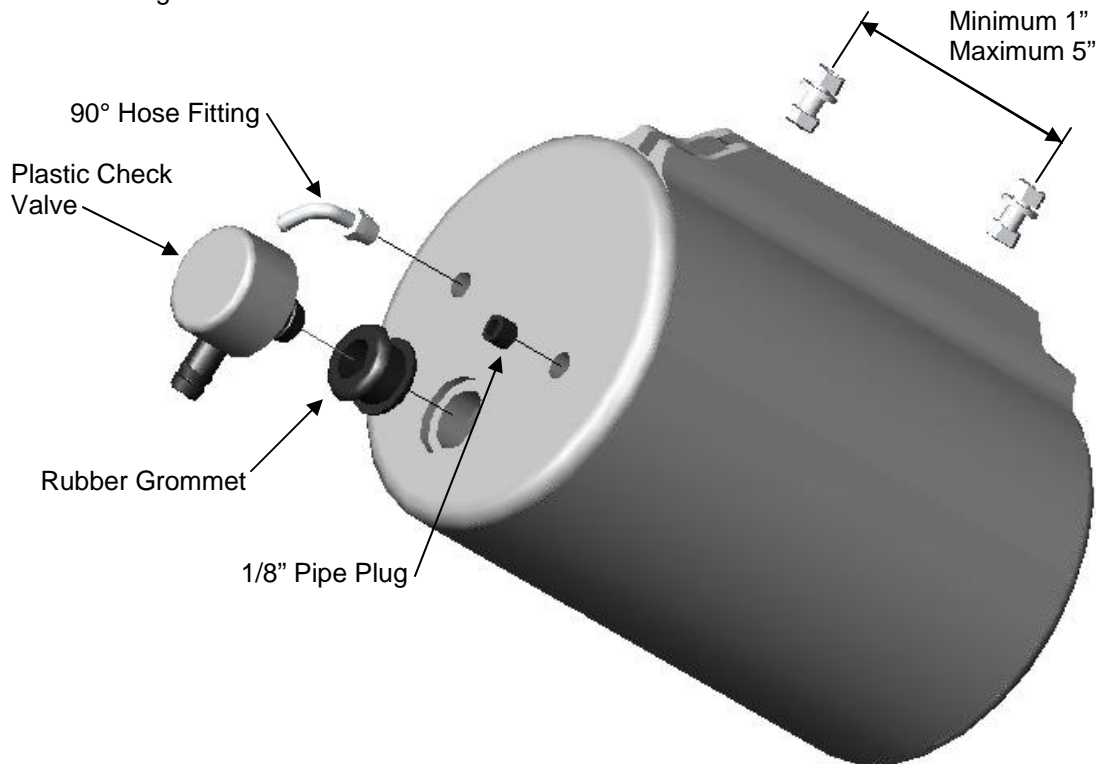

JEG'S
Performance Products

1-800-345-4545 jegs.com