

Installation Instructions for 300110

Coated Header

For: 1969-91 Chevrolet Blazer, Suburban, Yukon & 1 Ton Crew Cab (2WD)
1969-87 Chevrolet 1/2, 3/4. And 1 Ton Pickup (2WD)
265-400 Small Block Engines



WARNING: These headers are legal for Off Highway use (except in California or states that have adopted California emission standards) or Racing use (which may never be used on a Highway), or for use on pre emission controlled motor vehicles/motor vehicle engines (pre 1966 domestic vehicles certified to California standards, pre 1968 domestic vehicles certified to Federal standards and all pre 1968 Foreign vehicles) **Only**.

Please read and understand these instructions completely prior to starting work.

Check to make sure you received the proper parts for your application. The header number will be stamped on the engine flange. If you are unsure you have received the proper parts call before you start work.

Be sure to work safe! Whenever you work under the vehicle be sure that it is located on level, solid ground and is supported by adequate safety stands! **Remember: Hot asphalt will not support most jack stands!**

Many factors affect the installation of headers, some of which are broken or aftermarket motor mounts, accidents that impact the configuration of the frame, and/or the installation of different engines or aftermarket cylinder heads.

Attention Customers breaking in new engines: Due to the extreme heat generated during the break-in process, the appearance of the ceramic coating may be altered in certain areas. The protection characteristics and thermal barrier properties of the coating is never compromised. It is recommended that a cast iron manifold or old set of headers be used for this process.

Notice: The coating of these headers can be marred or scratched during installation. Please use the ceramic header installation kit that is included with this kit. This will reduce the possibility of getting scratches, nicks or discoloration of the headers while installing them.

DISASSEMBLY

1. Disconnect the negative battery cable from the battery.
2. If a car lift is not available, raise the vehicle 2 feet or higher and support with adequate safety stands. Make sure the vehicle is on a flat solid surface and is stable.
3. Remove bolts attaching head pipes stock manifolds and move the stock headpipes out of the way for header installation.
4. Remove the Oil Dipstick Tube, Starter, Clutch linkage (on std trans cars), Oil Filter, and Oil Filter Adapter.
5. Remove the Spark Plugs Wires and spark Plugs.
6. If the A/C Compressor, or Alternator are mounted to the manifolds, remove these items.
7. Remove the stock Exhaust manifolds.
8. Remove any remaining gasket or carbon deposits from the head surface. The use of a gasket scraper and or a gasket removal product may help.

INSTALLATION

1. Starting on the Driver's side, slip the header roughly into position from the bottom.
2. Using the supplied Header bolts, slip the gasket in place and start all of the header bolts, and tighten them evenly.
3. Replace the Oil Filter, the Oil Dipstick Tube, and Clutch Linkage
4. **NOTE:**
 - 1967 Models, Modify the clutch linkage as shown in Illustration A.
 - Some models may need to modify the shift linkage per Illustration B.
 - Models with Alternator on the Driver's side may need to purchase Alt Bracket part # 555-30780.
 - Models with Power Steering Bracket on Driver's side may need to fabricate spacer as shown in Illustration C.
 - Models with A/C Compressor on Driver's side may need to purchase bracket part # 555-30782, see Illustration D.



1-800-345-4545 jeps.com

5. Slip the Passenger side header into position from the bottom.
6. Using the supplied Header bolts, slip the gasket in place and start all header bolts, leaving them loose for access to the starter.
7. Slip the starter back in to place with the header loose, and tighten the starter bolts. Carefully reroute the wires to the starter ensuring that they are away from the header. Then tighten all header bolts evenly
8. Check transmission cooler lines and move away from header as necessary.
9. Re install spark plugs and wires, making sure the wires are clear of the header tubes.
10. If reusing the existing exhaust system cut and modify as necessary to connect to the headers using JEGS Reducers (sold separately)
11. Connect the negative battery cable.

IMPORTANT CHECK LIST

- Be sure that all brake lines and fuel lines are clear of headers and/or connector pipes.
- All spark plug wires, battery cables, or other electrical components should be clear of headers & connector pipes.
- If dipstick tube was removed, make sure it is installed properly and that the dipstick has been replaced.
- Double-check the tightness of all bolts including brackets and accessories.

STARTING THE ENGINE

Start the engine and allow it to warm up to operating temperature. Check for any unusual noises or exhaust leaks. If every thing is OK, stop the engine and tighten all bolts while the engine is still warm.

NOTE: Check the bolts periodically to make sure they have not loosened. Re-tighten after the first 500 miles and then again at 1000 miles.

PARTS LIST

Qty	Description
1	Left side header
1	Right side header
2	Header gaskets
12	3/8-16X3/4", Header Bolts
6	3/8-16 x1" Collector Hex head bolts
6	3/8-16 Hex Nuts
6	3/8" Lock washers
2	Collector gaskets

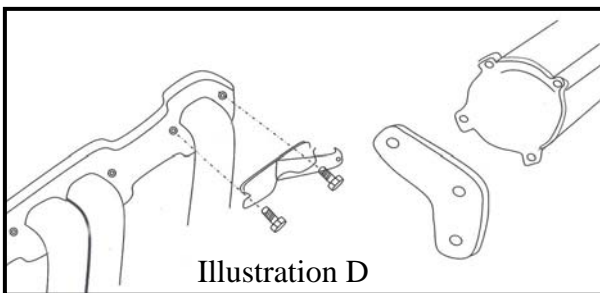
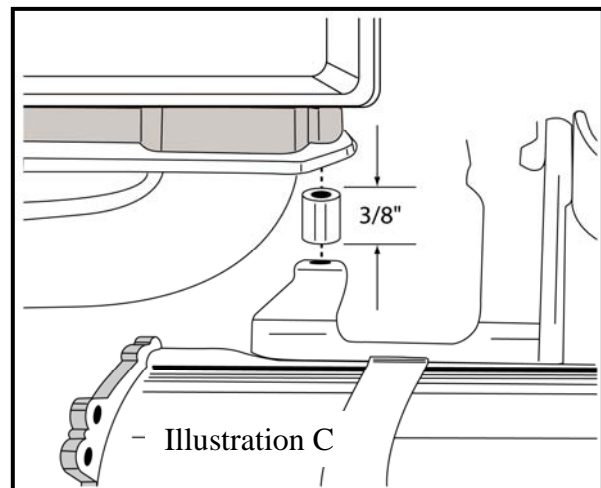
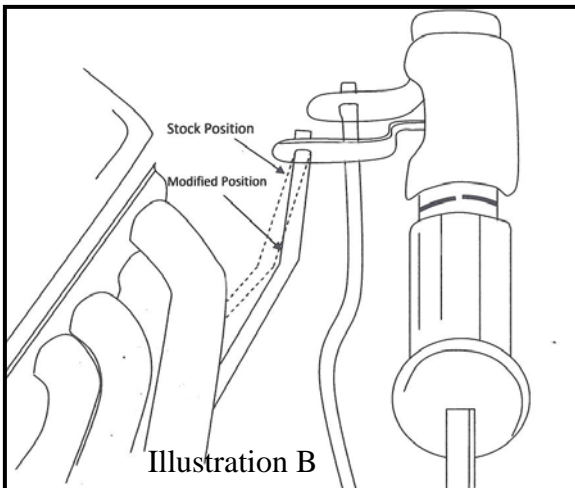
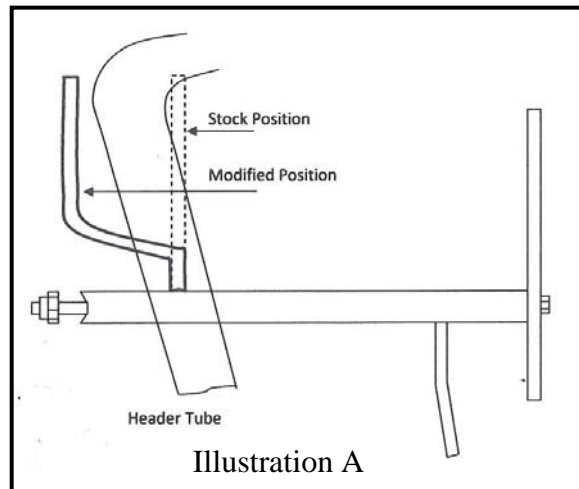

1-800-345-4545 jegs.com